

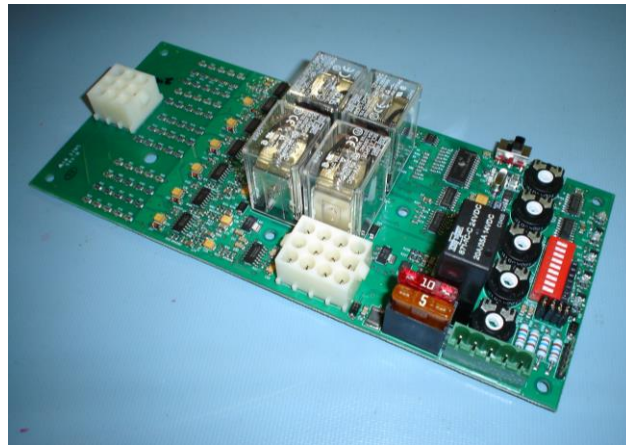

VTSC100

Transfer Switch Controller



VTSC100 *Transfer Switch Controller*

Installation and User Manual

Full Version File: MAN-0068 R1.4, VTSC100 User Manual.doc (September 2013)

Thank You for Purchasing This DynaGen Product

Please Read Manual before Installing Unit

Receipt of Shipment and Warranty Return Information

Upon receipt of shipment, carefully remove the unit from the shipping container and thoroughly examine the unit for shipping damage. In case of damage, immediately contact the carrier and request that an inspection report be filed prior to contacting DynaGen.

All returned items are to be shipped prepaid and include a Return Material Authorization (RMA) number issued by DynaGen. RMA forms are available by contacting DynaGen Technical Support through the contact methods listed below.

Limited Warranty

For warranty information refer to the standard terms and conditions of sale at <http://www.dynagen.ca>.

Dynagen VTS Webpage

For up-to-date manuals and other information please see the VTS section of the Dynagen website at: <http://www.dynagen.ca/products/VTS.htm>

Table of Contents

INTRODUCTION	4
SPECIFICATIONS	5
VTSC100 Identification	6
Wiring Guidelines	7
12/24VDC Operation	7
Terminal Description	8
Outline Dimension Drawing	9
TIMER SETTINGS	10
TDES	11
TDNE	11
TDEN	11
TDEC	11
TDNP – Delay on Neutral	11
Test point measurements	12
120/277 System Voltage Setting	13
50/60 Hertz setting	14
Load/No load	15
Over/Under Voltage setting	16
Over/Under Frequency setting	17
DIP SWITCH SETTING – MASTER CHART	18
MANUAL TEST CONFIGURATION	19
LED INDICATIONS	21
LOGIC SEQUENCE	22

INTRODUCTION

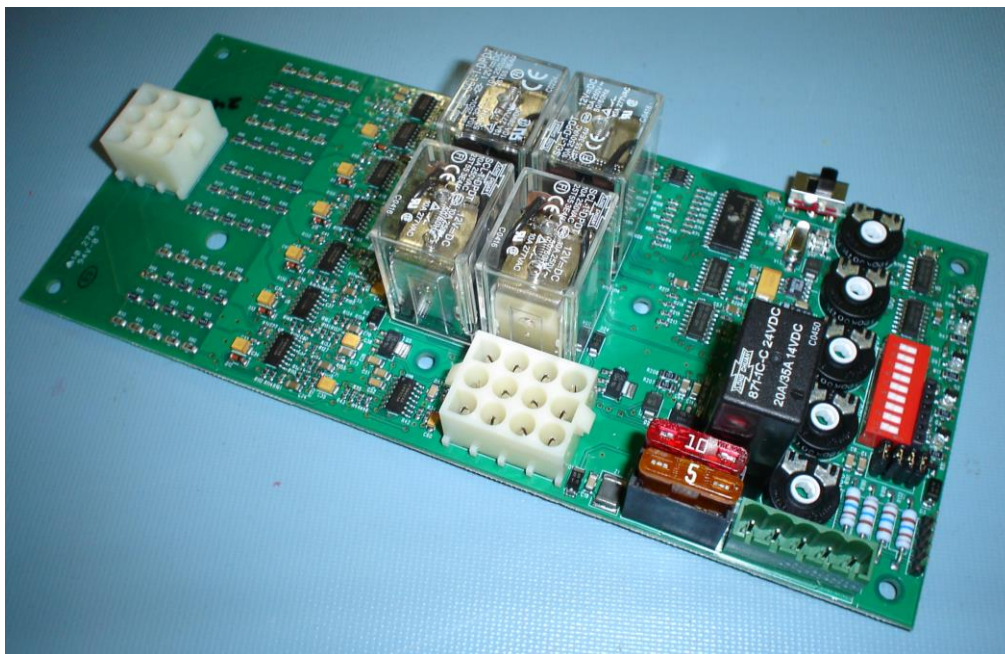

The VTSC100 Transfer Switch Controller provides all the necessary timing functions for the proper operation of DynaGen's Vigilant Series Automatic Transfer Switch. The VTSC100, in conjunction with DynaGen's Vigilant Series Transfer Switch, allows customer adjustability for specific transfer conditions. In addition to adjustability, specific transfer conditions are also represented by LED illumination from the external annunciation board.

The VTSC100 allows customer adjustability of transfer conditions such as engine start delay, delay on neutral (available on 600A – 1250A), normal to emergency delay, emergency to normal delay, and engine cooldown. Simple potentiometer variations will determine the amount of time the VTSC100 will wait before activating specific outputs to control transfer switch conditions. Test points are provided on the VTSC100 for the accurate calibration of time delays.

As the VTSC100 controls DynaGen's Vigilant Transfer Switch functions, specific conditions are shown by the controller on the external LED board. Specific LED's will be illuminated or flashing depending upon the condition or status of the controller. The VTSC100 will display status via the external LED board when the transfer switch has been initiated to be in the normal position, emergency position as well as when a transfer is initiated to go in to neutral position. A status LED from the external LED board is also used to display to the user when a power failure is simulated. When a utility failure is simulated, either manually by the user or automatically by the engine exerciser, an LED from the VTSC100's external LED board indication this condition will illuminate.

VTSC100 Specifications



VTSC100 does not support Delta configurations.

DC Voltage Rating	12/24 VDC (Voltage Range 9 - 30 VDC)		
DC Power Cons.	25mA @ 12 VDC		
Current Rating	10A remote start dry contacts		
Control Setting Ranges.	Function	Range	Default Setting
	Time Delay Engine Start	3-32 seconds	13 seconds (1.56Vdc @ TP J2-2)
	Time Delay Transfer to Emergency	11-64 seconds	21 seconds (0.78Vdc @ TP J2-3)
	Time Delay Transfer to Normal	9-256 seconds	256 seconds (5.00Vdc @ TP J2-4)
	Time Delay Engine Cooldown	0-256 seconds	256 seconds (5.00Vdc @ TP J2-1)
	Time Delay Neutral Position* (see note below)	0-64 seconds	10 seconds (0.78Vdc @ TP J2-5)
	Normal Line Sensing Under Voltage	Dropout (11-18%) Pickup (6-13%) (+/- 2% accuracy)	Dropout (18%) Pickup (13%) (+/- 2% accuracy)
	Normal Line Sensing Under Frequency	5-12% (+/- 1% accuracy)	12% (+/- 1% accuracy)
	Emergency Line Sensing Under Voltage	Dropout (11-18%) Pickup (6-13%) (+/- 2% accuracy)	Dropout (18%) Pickup (13%) (+/- 2% accuracy)
	Emergency Line Sensing Under Frequency	5-12% (+/- 1% accuracy)	12% (+/- 1% accuracy)
Over/Under Voltage Sensing	Sensing is L-N¹. Dropout (11-18%) Pickup (6-13%) adjustable Percentage above or below normal voltage to recognize an unacceptable voltage condition. (+/- 2% accuracy)		
Over/Under Frequency Sensing	5-12% adjustable Percentage above or below normal freq to recognize an unacceptable frequency condition. (+/- 1% accuracy)		
Test Input	Included for remote test switch		
Test switch	Included		
Overall Dimensions	8.511" x 3.75" x 1.7"		

*Feature only included on VTSC100-(240/480)-(12/24)-D Boards. Not on X types.

¹One of the connected L-N phases must be below the under-voltage threshold to initiate transfer sequence.

VTSC100 Product Number Identification



The Vigilant Transfer Switch controller product numbering scheme provides significant information pertaining to a specific model. The product Number Identification Table (see Table 1) provides the required information. An example is offered to initially simplify the process.

A product number VTSC100-XXX –XX-X would consist of a combination of information from the following table.

TABLE1: IDENTIFICATION TABLE

Position 1-7	Position 9-11	Position 13-14	Position 16
Series	AC Voltage	DC Voltage	Neutral Delay
VTSC100	240=240VAC 480=480VAC	12=12VDC 24=24VDC	D=Neutral Delay X=No Neutral Delay

Example: The product number VTSC100-480-12-D would be described as follows:

The transfer switch controller was designed to operate in a single or three phase 480VAC/12VDC system. The controller is capable of performing the Delay on Neutral (TDNP) function.

WIRING GUIDELINES

VTSC100 does not support Delta configurations.

1. DO NOT use wire smaller than 16 AWG on terminals 1, 2, 3 and 4 of the 5-position connector for +12/24VDC, battery ground, RSC1 or RSC2 connections.
2. DO NOT use wire smaller than 18 AWG on terminal 5 of the 5-position connector for the test switch input.
3. DO NOT exceed the maximum rated current and voltage on the Remote Start Contacts (RSC1 & RSC2). Do not exceed 10 amps for RSC1 & RSC2.
4. The remote start connections from the timer module are internally fused. **If fusing is replaced, use a 10 AMP automotive style fuse.**
5. Do not switch AC voltages with remote start connections from timer module.
6. Jumpers must be installed in the 12/24VDC jumper location on the VTSC100 for 12VDC operation.

12/24 VDC OPERATION

The VTSC100 controller is designed to operate in a 12 **OR** 24 VDC system voltage.

In 12VDC system operation, the controller requires that jumpers be installed in the 12/24VDC jumper location.

In 24VDC system operation, the controller requires that no jumpers be installed in the 12/24VDC jumper location.

A total of five jumpers need to be installed for 12VDC operation as illustrated.

Installing jumpers in the 12/24 VDC jumper locations for 24VDC system operation may damage the VTSC100 controller.

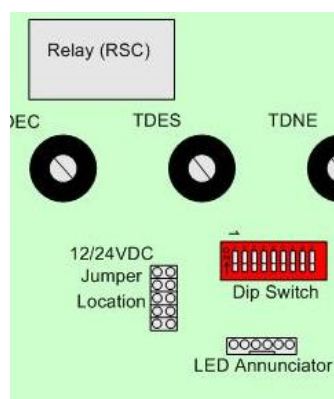

Jumper not installed for 24VDC

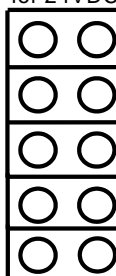

Jumper installed for 12VDC

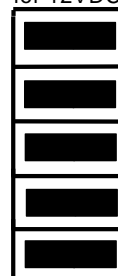

5-POSITION TERMINAL DESCRIPTION

Term #	Description
J27-1	+12/24 VDC Battery power terminal.
J27-2	Battery ground connection for the timer module. A good ground connection, directly from the battery , is required for proper operation.
J27-3	RSC1, provided for the connection of one lead from the remote start contacts of engine controller.
J27-4	RSC2, provided for the connection of one lead from the remote start contacts of engine controller.
J27-5	Test switch input (apply ground to simulate loss of utility)

9-POSITION TERMINAL DESCRIPTION

Term #	Description
J1-1	Normal Phase A
J1-2	Normal Neutral
J1-3	Neutral
J1-4	Normal Phase B
J1-5	Neutral
J1-6	Emergency Phase A
J1-7	Normal Phase C
J1-8	Emergency Phase C
J1-9	Emergency Phase B

12-POSITION TERMINAL DESCRIPTION

Term #	Description
J3-1	Emergency A 120V
J3-2	Not Used
J3-3	Not used
J3-4	Emergency Output B1
J3-5	Trip Coil AT1
J3-6	Trip Coil BT1
J3-7	Normal A 120V
J3-8	Normal A 120V
J3-9	Exerciser Input
J3-10	Normal Output A1
J3-11	Not used
J3-12	Exerciser Ground

VTSC100 GENERAL LAYOUT

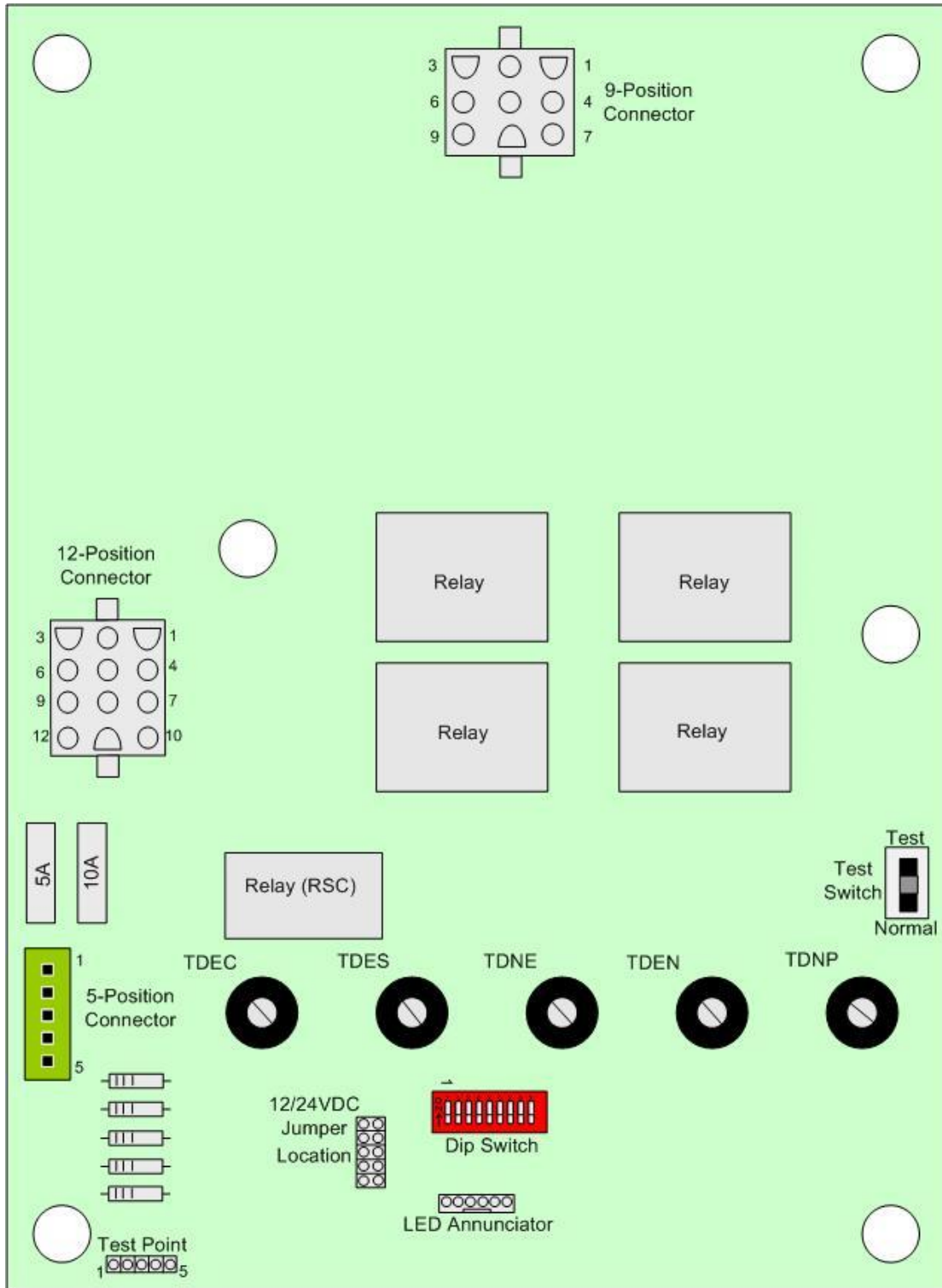

*Drawing not to scale

TIMER SETTINGS



DANGER: Never adjust settings with AC power on. This controller and transfer switch mechanism contain dangerously high voltage. Signs should be placed in transfer switch vicinity to indicate this important safety measure.



DANGER: Never adjust settings with AC power on. Completely isolate all sources of AC power from controller and transfer switch mechanism before making any adjustments.

All necessary timing functions of the VTSC100 are configurable through the use of on-board potentiometers (POTS). Each pot has a 270 degree adjustment rotation, and can be increased by turning the pot clockwise and decreased by turning the pot counter-clockwise using the included pot adjustors.

Note: The TDNP potentiometer is not included on the VTSC100-240-12-X version.

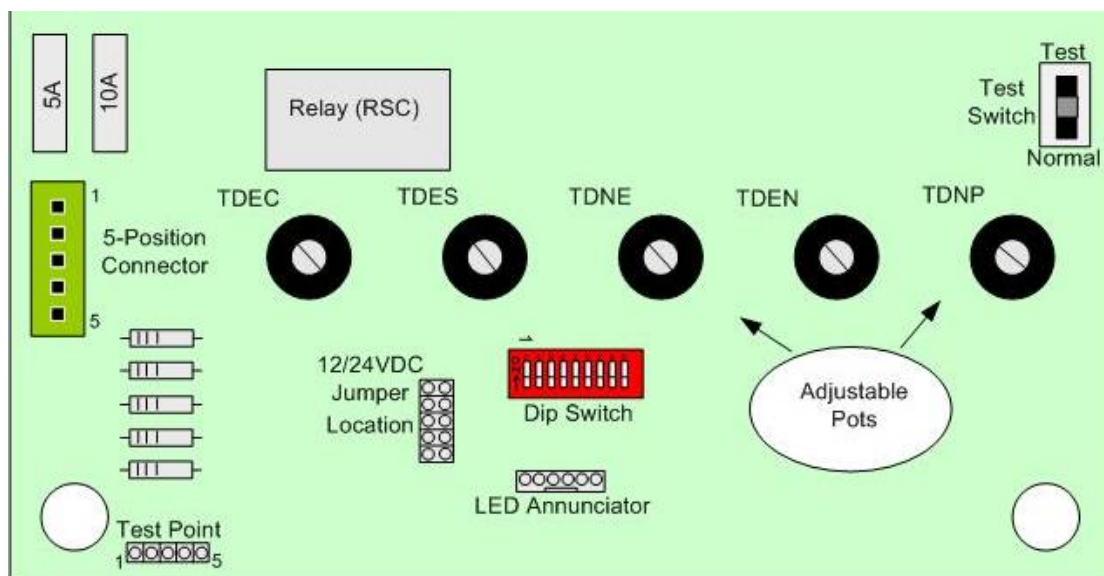

The following adjustable timing functions are included in the VTSC100. Any adjustments must be made by qualified electricians only. Accurate adjustments may be performed following the test point measurements described on page 12.

- 1: **TDEC:** Time Delay Engine Cool: Adjustable from 0 to 256 seconds. This delay allows the engine to continue running after the transfer switch returns to the normal position. When the VTSC100 recognizes that the transfer switch is in the normal position after an emergency to normal transfer, the generator will continue to run under a no load condition until the engine cool time delay has expired. Pot resolution is 1 second per each 20mV.
- 2: **TDES:** Time Delay Engine Start: Adjustable from 0 to 32 Seconds. This delay prevents unnecessary engine starts. When a utility failure is recognized by the VTSC100, the engine start time delay period must expire before sending a signal to the generators automatic start controller. If the utility source is restored before the time delay expires the transfer switch will stay in its normal position and no signal will be given for automatic start. Pot resolution is 1 second per each 160mV.
- 3: **TDNE:** Time Delay Normal to Emergency: Adjustable from 0 to 64 seconds. This delay allows the generator to stabilize before any load is transferred. When the VTSC100 recognizes that the generator has started, the transfer switch will wait until the normal to emergency time delay has expired before switching to the neutral and emergency position. This normal to emergency time delay allows the generator to be fully running before supplying power to a load. Pot resolution is 1 second per each 80mV.
- 4: **TDEN:** Time Delay Emergency to Normal: Adjustable from 0 to 256 seconds. This allows the utility source to be monitored for stability. When the VTSC100 recognizes that the utility source has been restored, the transfer switch will wait until the emergency to normal time delay has expired before switching to the neutral and normal position. This emergency to normal time delay allows the utility to be monitored for the set amount of time to confirm that it is fully restored and stable. Pot resolution is 1 second per each 20mV.
- 5: **TDNP:** Delay on Neutral time: Adjustable from 0 to 64 seconds. This delay allows the transfer switch to temporarily stop between normal to emergency and emergency to normal transfers. The temporary stop allows controlled isolation between the both normal and emergency sources. Performing a set time delay between normal to emergency and emergency to normal transfers allows controlled protection against both the normal and emergency power sources to ever become connected simultaneously. Pot resolution is 1 second per each 80mV. TDNP adjustments are optional and are only included on D type boards. X boards do not have this feature.

Test Point Measurements:

All timing adjustments may be accurately made by measuring the reference voltage supplied at the test point connector located on the VTSC100. A volt meter may be used to manually measure and adjust the time delay functions. Simply install the voltage meter between the proper test point terminal and ground. The following formula may be used for proper adjustments.

$$\text{Test Point voltage} = (\text{Desired time in seconds} / \text{Max time in seconds}) \times 5$$

Example: For a Time Delay Engine Start (TDES) of 10 Seconds

$$\text{Test Point voltage} = (10 / 32) \times 5$$

Test Point voltage = 1.5625 VDC for TDES

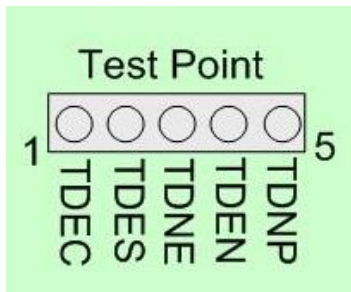
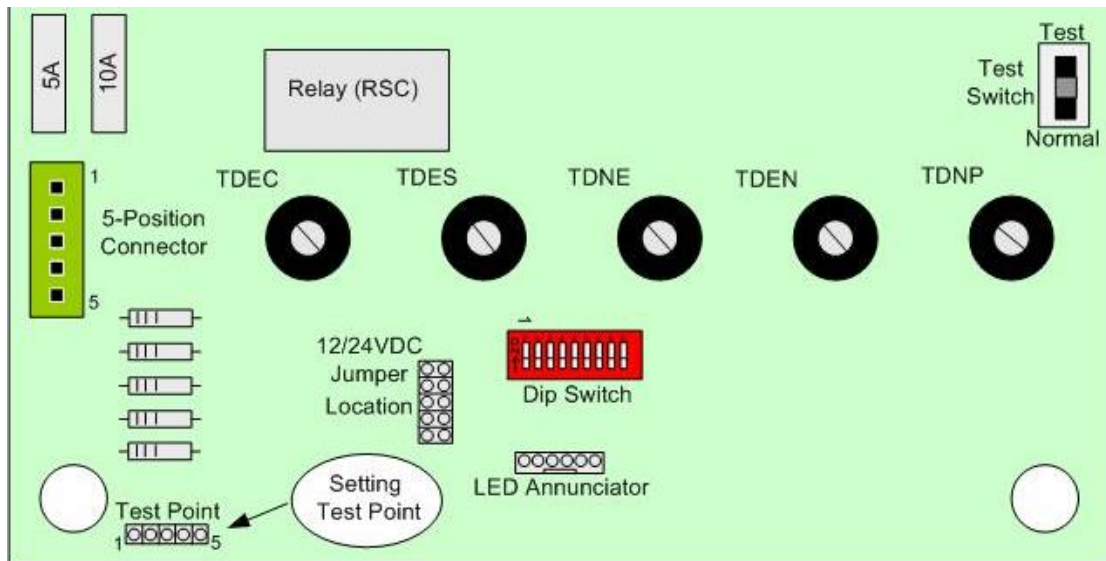
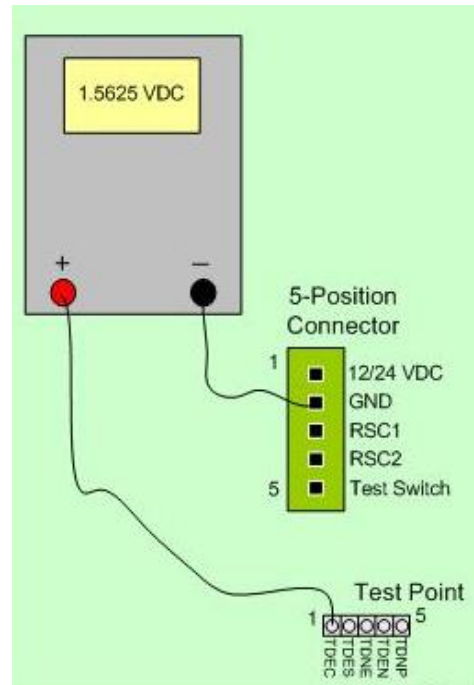

- Test point #1 = TDEC
- Test point #2 = TDES
- Test point #3 = TDNE
- Test point #4 = TDEN
- Test point #5 = TDNP

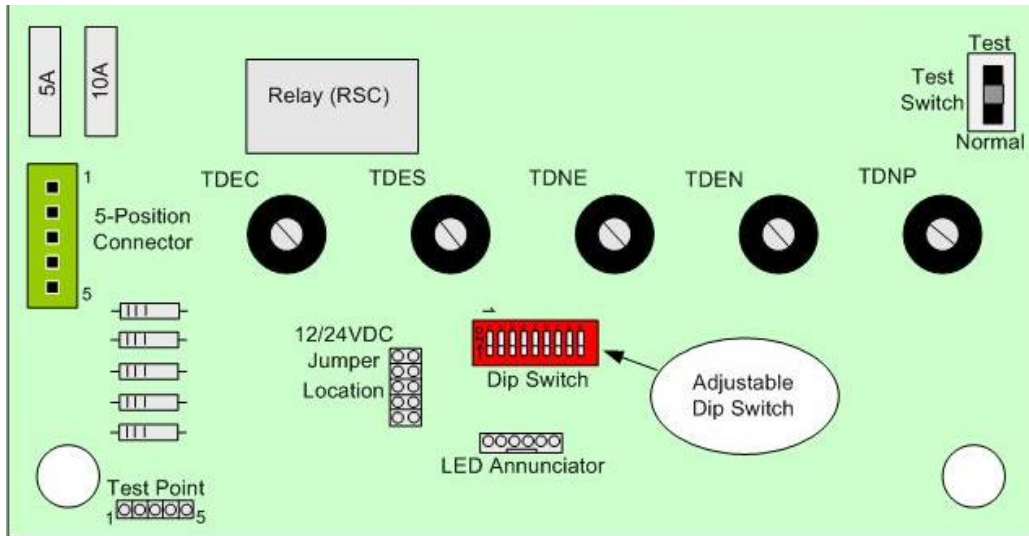

120/240 OR 277/480 VAC SYSTEM VOLTAGE SETTING



DO NOT ADJUST: Please note that this setting is factory set and must not be adjusted by the customer. Improper system voltage settings may cause the controller to function improperly. 120/240 and 277/480 VAC systems require specific hardware, so simply adjusting this setting in the field will not convert the system voltage of the board.

The dip switch in location #1 on the VTSC100 is used at the factory to set the unit for 120/240 or 277/480 VAC systems.

Boards with the following Product Number Identification must have switch location #1 in the OFF position:

1. VTSC100-240-12-X
2. VTSC100-240-12-D

Boards with the following Product Number Identification must have switch location #1 in the ON position:

1. VTSC100-480-12-D

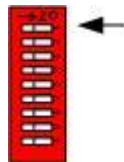

50/60 HERTZ SETTING



Please note that this setting is factory set for a 60 HZ system. If the unit is being installed into a 50 HZ system the unit will need to be manually adjusted using the 50/60 HZ setting. Improper system frequency settings may cause the controller to function improperly.

The dip switch located on the VTSC100 is used to set the unit for 50 or 60 Hz systems. When switch location #2 is ON, the system is configured for 60 Hz. When switch location #2 is OFF, the unit is configured for 50 Hz systems.

The 50 /60 Hz connection is used as follows:

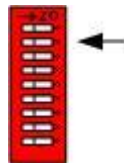

Function		Dip Switch
50/60 HZ		#2
	50 HZ	OFF
	60 HZ	ON

LOAD / NO LOAD SETTING

The dip switch located on the VTSC100 is used to set the load / no load setting. When switch location #3 is ON, the system is configured for a load condition. When switch location #3 is OFF, the unit is configured for a no load condition.

This setting applies to the engine exerciser only. This setting allows for exercising or testing of the transfer switch under a load or no load condition.

When exercising the transfer switch under a load condition the switch will transfer to generator emergency power. When exercising the transfer switch under a no load condition the switch will not transfer and stay in the normal power position.

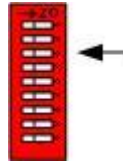

Function		Dip Switch
Load/No Load		#3
	No Load	OFF
	Load	ON

OVER/UNDER VOLTAGE SETTINGS



Please note that the default factory setting is for an 18% dropout and 13% pickup failure range. The VTSC100 is set for a less selective condition (higher percentage selection) as default. The default setting is an appropriate operating range especially if the transfer switch is being installed into an electrical system prone to fluctuations. A narrower operating range may be selected if appropriate.

The dip switch located on the VTSC100 is used to set the Over/Under voltage setting. Depending upon the positions of Dip Switch locations 4, 5 and 6 the VTSC100 will determine when to recognise a utility voltage failure. When switch location #4, 5, and 6 are ON, the system is configured for an 11% Dropout range and a 6% Pickup range. An example of an 11% dropout and a 6% pickup range for a standard 120VAC system would be as follows: the controller would recognise a failure at 133.2V or at 106.8V. When the voltage goes above 133.2V a failure is recognized. The failure will be recognized until the voltage goes below 127.2V. See example for a 120V system with an 11% dropout and a 6% pickup.

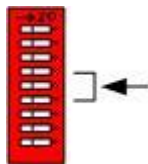

Function			Dip Switch		
			#4	#5	#6
Under/Over Voltage	%				
	DO	PU			
	18	13	OFF	OFF	OFF
	17	12	OFF	OFF	ON
	16	11	OFF	ON	OFF
	15	10	OFF	ON	ON
	14	9	ON	OFF	OFF
	13	8	ON	OFF	ON
	12	7	ON	ON	OFF
	11	6	ON	ON	ON

Over voltage diagram

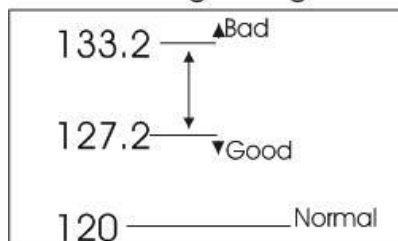

Under voltage diagram

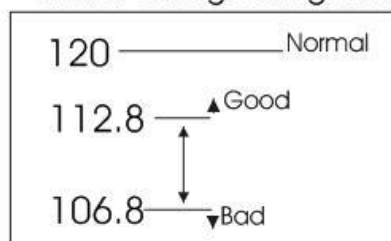

OVER/UNDER FREQUENCY SETTINGS



Please note that the default factory setting is for a 12% failure range. The VTSC100 is set for a less selective condition (higher percentage selection) as default. The default setting is an appropriate operating range especially if the transfer switch is being installed into an electrical system prone to fluctuations. A narrower operating range may be selected if appropriate.

The dip switch located on the VTSC100 is used to set the Over/Under frequency setting. Depending upon the positions of dip switch locations 7, 8 and 9 the VTSC100 will determine when to recognize a utility failure. When switch location #7, 8, and 9 are ON, the system is configured for a 5% failure range. If the utility frequency varies to 5% over or 5% under the normal system utility frequency, the frequency will be recognized as a failure. For example if dip switch locations 7, 8 and 9 are ON, the over frequency setting would be 63Hz for 60Hz systems. When the frequency goes above 63Hz a failure is recognized. When the frequency goes below 57Hz a failure is recognized. See example for a 120V system with a 5% Over/Under frequency rating.

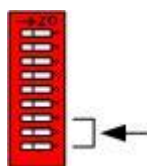

Function		Dip Switch		
Under/Over Frequency	% Range	#7	#8	#9
	12	OFF	OFF	OFF
	11	OFF	OFF	ON
	10	OFF	ON	OFF
	9	OFF	ON	ON
	8	ON	OFF	OFF
	7	ON	OFF	ON
	6	ON	ON	OFF
	5	ON	ON	ON

Over freq. diagram

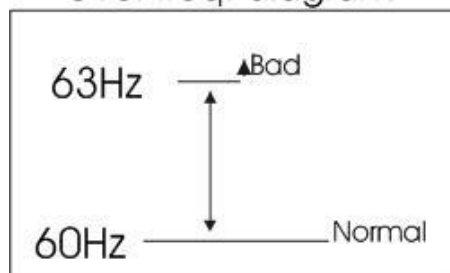

Under freq. diagram

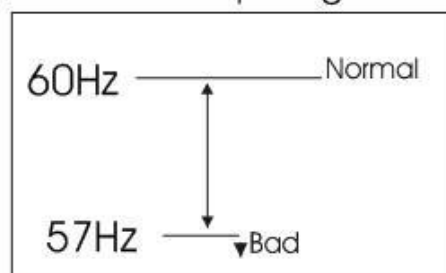

DIP SWITCH SETTINGS – MASTER CHART



Function		Dip Switch Locations									
		#9	#8	#7	#6	#5	#4	#3	#2	#1	
Under/Over Frequency	% out										
	12	OFF	OFF	OFF	-	-	-	-	-	-	
	11	OFF	OFF	ON	-	-	-	-	-	-	
	10	OFF	ON	OFF	-	-	-	-	-	-	
	9	OFF	ON	ON	-	-	-	-	-	-	
	8	ON	OFF	OFF	-	-	-	-	-	-	
	7	ON	OFF	ON	-	-	-	-	-	-	
	6	ON	ON	OFF	-	-	-	-	-	-	
	5	ON	ON	ON	-	-	-	-	-	-	
Under/Over Voltage	%										
	DO	PU									
	18	13	-	-	-	OFF	OFF	OFF	-	-	
	17	12	-	-	-	OFF	OFF	ON	-	-	
	16	11	-	-	-	OFF	ON	OFF	-	-	
	15	10	-	-	-	OFF	ON	ON	-	-	
	14	9	-	-	-	ON	OFF	OFF	-	-	
	13	8	-	-	-	ON	OFF	ON	-	-	
	12	7	-	-	-	ON	ON	OFF	-	-	
	11	6	-	-	-	ON	ON	ON	-	-	
Load/No Load											
	Load		-	-	-	-	-	-	ON	-	-
	No Load		-	-	-	-	-	-	OFF	-	-
50/60 HZ											
	50		-	-	-	-	-	-	-	OFF	-
	60		-	-	-	-	-	-	-	ON	-
120/277 VAC											
	120		-	-	-	-	-	-	-	-	OFF
	277		-	-	-	-	-	-	-	-	ON

MANUAL TEST CONFIGURATION



DANGER: Never adjust settings with AC power on. This controller and transfer switch mechanism contain dangerously high voltage. Signs should be placed in transfer switch vicinity to indicate this important safety measure.



DANGER: Never adjust settings with AC power on. Completely isolate all sources of AC power from controller and transfer switch mechanism before making any adjustments.

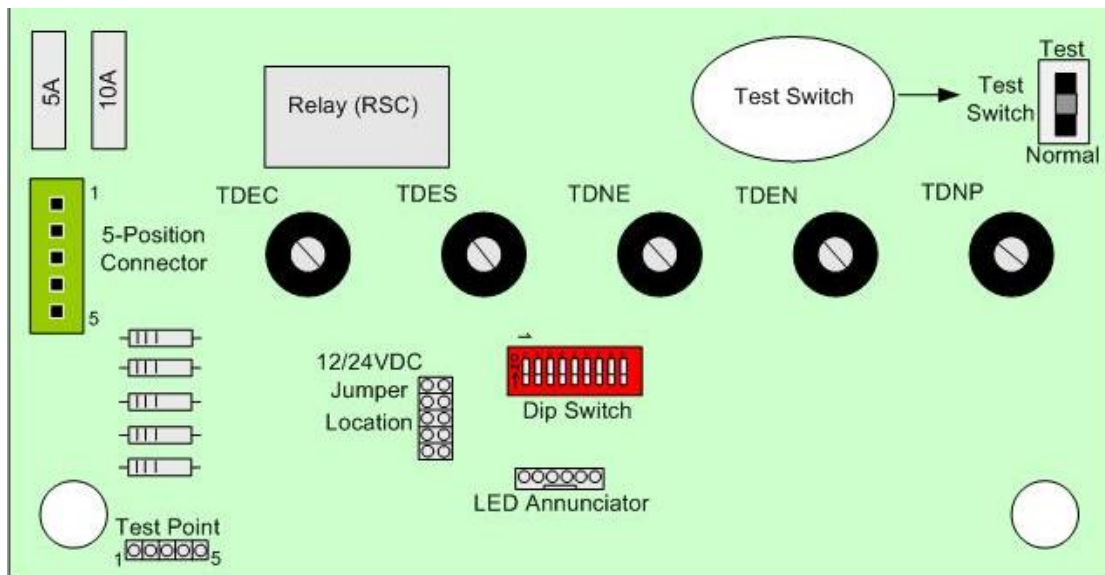

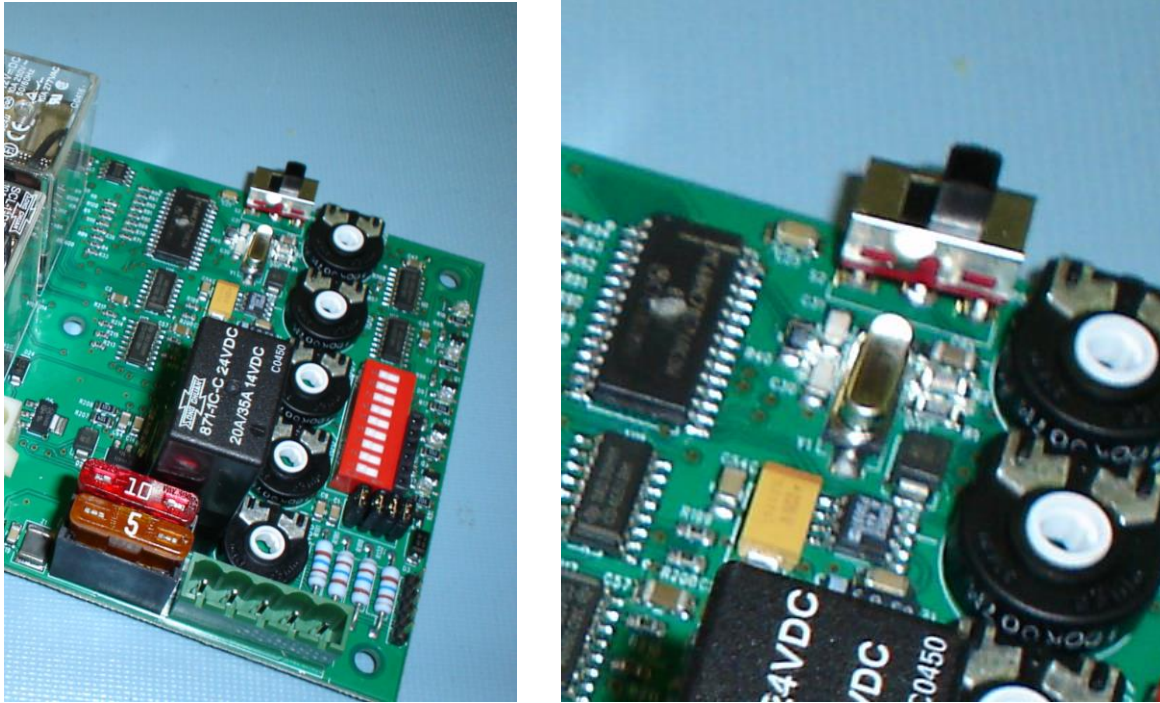

The VTSC100 has an on board test switch included for manual testing of the transfer switch mechanism. The VTSC100 test switch may be used to test the system under a load condition. Testing may be performed simply by setting the test switch to the “test” position. The test position would be the position farthest from the adjustable pots.

Test Switch

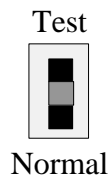

Test Switch





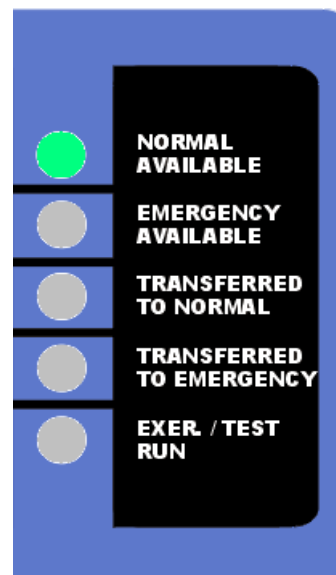
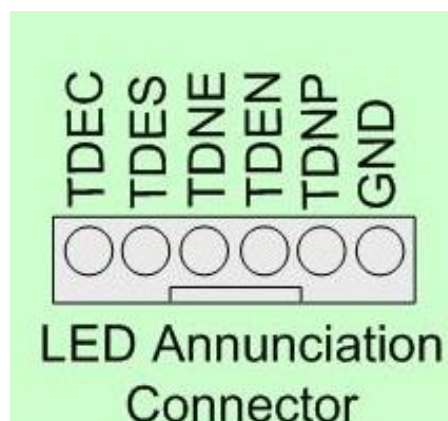
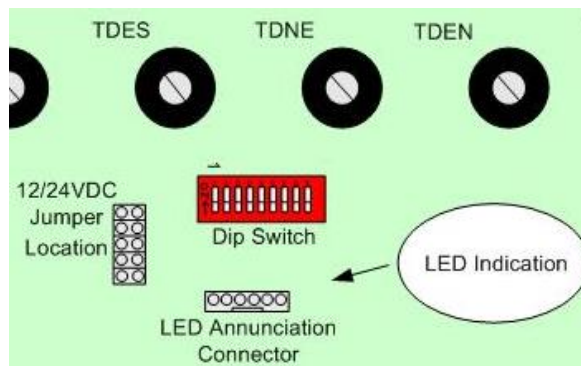

Please note that this setting is factory set with the test switch in the normal position. Installing controller with test switch set to the “test” position will initiate an engine start up, even when the utility source is within acceptable limits.

LED INDICATIONS

The VTSC100 includes an on board connector for LED indication. This 6-pin connector is easily attached to an external LED board. The connector and LED board are attached by a cable which has a locking connection to eliminate improper installation. The external LED board will indicate the status of the VTSC100. The LED board has five LED's to represent specific conditions. Conditions include normal utility source, emergency power source, transfer to normal (TTN) command, transfer to emergency (TTE) command, and exerciser/test condition. Specific LED's may be illuminated solid or flashing depending on the status of the VTSC100. For a full description of the LED indications see the following display and table.



LED DESCRIPTION

LED DESCRIPTION	LED COLOR	LED STATUS	Indication
Normal Available 	Green	Solid	The Normal LED will represent the utility power source. An illuminated LED indicates that the utility power source is available and within acceptable range.
Emergency Available 	Red	Solid	The Emergency LED will represent the emergency power source. An illuminated LED indicates that the emergency power source is available and within acceptable range.
Transfer to Normal (TTN) 	Green	Solid	This indicates that the transfer switch has been commanded to go to the normal position. The led will also be illuminated during engine start time delay as well as normal to emergency time delay.
		Flashing	This indicates that the transfer switch will be commanded to transfer to the neutral position after any delay has expired.
Transfer to Emergency (TTE) 	Red	Solid	This indicates that the transfer switch has been commanded to go to the emergency position. The led will also be illuminated during emergency to normal time delay
		Flashing	This indicates that the transfer switch will be commanded to transfer to the neutral position after any delay has expired.
Exer./Test Run 	Yellow	Solid	This indicates that the VTSC100 is being controlled by either an exerciser or test command. When the transfer switch is functioning from an exerciser or manual test the Exerciser/Test LED will be illuminated.
Note: TTN and TTE lights will alternate blinking when the neutral delay is in effect.			

LOGIC SEQUENCE

The VTS series transfer switch in combination with DynaGen's VTSC100 timing module will allow for the automatic transfer of an electrical load to a stand-by power source in the event of an over/under voltage or frequency condition on any or all phases of the normal power supply.

In the event of a drop or loss of utility power, the onboard VTSC100 sensing circuitry will begin the initiation of the transfer process. Upon initial sensing of a loss of utility power the Vigilant series transfer switch is specifically designed to allow an engine start time delay period (TDES) to expire before starting the generator. This engine start time delay is user adjustable from the VTSC100 preventing unnecessary engine starts from a temporary loss of utility. In the event the utility source is not restored after the engine start time delay has expired the remote contacts will close sending a signal to the generator's automatic start controller.

When the VTSC100 senses that the generator has started, and is within acceptable limits, the transfer switch will wait until the normal to emergency time delay (TDNE) has expired before switching to the neutral position. While in the neutral position the transfer switch will transfer back to normal supply if the utility is restored. With no utility source the transfer switch will stay in the neutral position until the delay on neutral time has expired allowing the transfer switch to temporarily stop at the neutral position during either the normal to emergency or emergency to normal transfers. The temporary stop allows controlled isolation between both normal and emergency sources. After the neutral delay has expired the transfer switch will complete the transfer to the destination source. All connected loads will be transferred to the emergency power source.

While the transfer switch is in the emergency position, the VTSC100 will constantly monitor the utility source voltage and frequency status. Once the utility source is restored the transfer switch will wait until the emergency to normal time delay (TDEN) has expired before switching to the neutral position. The TDEN delay is user adjustable from the VTSC100 to prevent unnecessary transfers caused by momentary utility restoration conditions. If the utility source remains stable after the emergency to normal time delay expires the transfer switch will transfer to the neutral position. The transfer switch will stay in the neutral position until the delay on neutral time has expired. If the utility source fails during this delay period, there will be a transfer back to the emergency position. When the delay on neutral time expires the transfer switch will transfer to the normal position. All connected loads are transferred to the normal power source.

When connected loads are transferred back to the normal power source an engine cooldown period (TDEC) will be initiated allowing the generator to run in a no load condition. This engine cooldown time delay is user adjustable from the VTSC100 allowing the generator to continue running for an adjustable period after the normal utility is restored.